

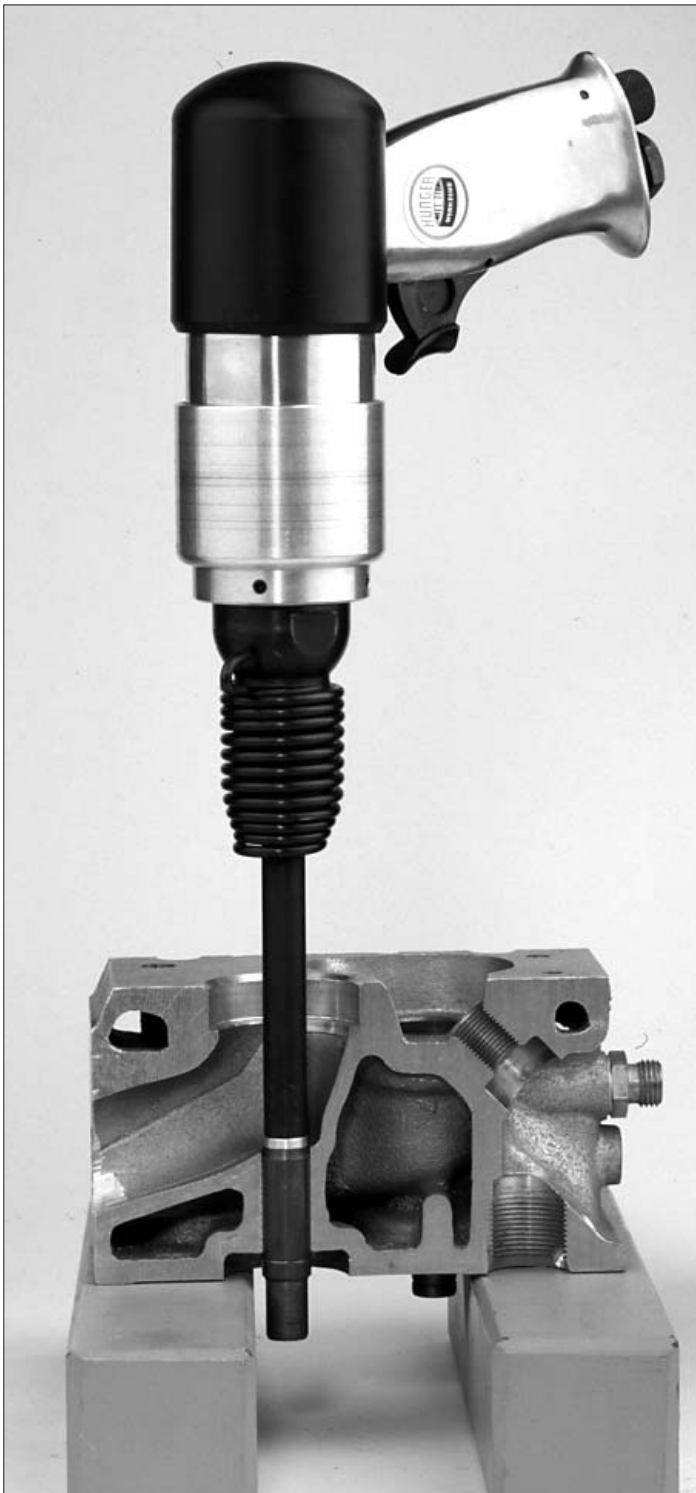

Hunger PVM1 Valve Guide Tool



The Hunger PVM1 is designed to remove worn-out valve guides from the cylinder head and to insert new valve guides into the cylinder head.

The PVM1 is particularly suitable for motorcycle and automotive workshops.

The Hunger PVM1 includes an air hammer and guide drivers fitting to the diameters of the valve guides to be removed or installed.

Removing of a valve guide is quite easy.

Fit the appropriate guide driver to the air hammer.

Place the pilot end of the guide driver into the valve guide to be removed and then switch on air supply.

The valve guide will be forced out of the cylinder head by the short strokes of the air hammer.

When installing a new valve guide, a soft expander washer should be fitted on the pilot end of the guide driver to protect the valve guide from damage.

The PVM1 can be also used for removing valve seat rings.

First a groove is cut into the valve seat ring with a Hunger Valve Seat Refacing Tool.

Then the expanding jaws of an adapter are forced into the groove.

Thereafter the seat ring is driven out of the cylinder head by applying strokes of the air hammer to the adapter.

PVM1 Components

Item Description

Part No.

1. PVM1 Kit for removing and installing valve guides

250 10 500

Scope of supply:
Air hammer,
3 pcs. guide drivers 7, 8 & 9mm diam.,
5 pcs. each protecting washers 7, 8 & 9mm diam.
and storage case

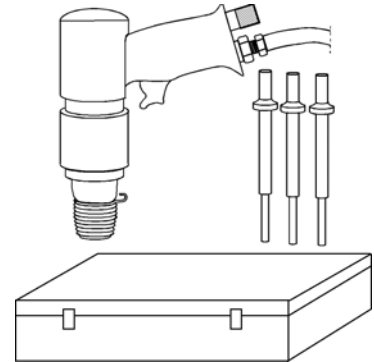

2. Guide drivers for removing and installing valve guides

Nominal: diameter	Suitable for valve guide diameter range:	
5 mm	4,9 - 5,4 mm	250 20 050
5,5 mm	5,4 - 5,9 mm	250 20 055
6 mm	5,9 - 6,4 mm	250 20 060
6,5 mm	6,4 - 6,9 mm	250 20 065
7 mm	6,9 - 7,9 mm	250 20 070
8 mm	7,9 - 8,9 mm	250 20 080
9 mm	8,9 - 9,9 mm	250 20 090
10 mm	9,9 - 10,9 mm	250 20 100
11 mm	10,9 - 11,9 mm	250 20 110
12 mm	11,9 - 12,9 mm	250 20 120



3. Protecting washers

(5 psc each) for nominal diam.:

5 mm	250 22 050
5,5 mm	250 22 055
6 mm	250 22 060
6,5 mm	250 22 065
7 mm	250 22 070
8 mm	250 22 080
9 mm	250 22 090
10 mm	250 22 100
11 mm	250 22 110
12 mm	250 22 120



4. Adapter heads for removing valve seat rings

Adapter head type A for ring ID 25 - 35 mm	250 15 250
Adapter head type B for ring ID 35 - 45 mm	250 15 350

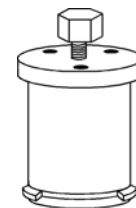

5. Seat ring drivers for the adapter heads

Seat ring driver 11,8mm diam.	250 15 118
Seat ring driver 12,8mm diam.	250 15 128
Seat ring driver 13,8mm diam.	250 15 138



Ludwig Hunger GmbH

Graefelfinger Str. 146
81375 Munich/Germany

Tel.: +49 89 7091-0
Fax: +49 89 7091-26

info@ludwig-hunger.de
www.ludwig-hunger.de