

HUNGER

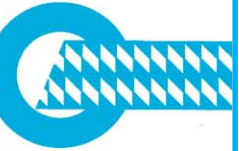

Hunger VD4HD/0°

**Portable Machine
for refacing flat seating surfaces up to 500mm diam.**



**The portable VD4E/0° is the first choice
for refacing the seating surfaces
on cylinder heads, cylinder liners and engine blocks
of large diesel engines**

Hunger VD4HD/0°

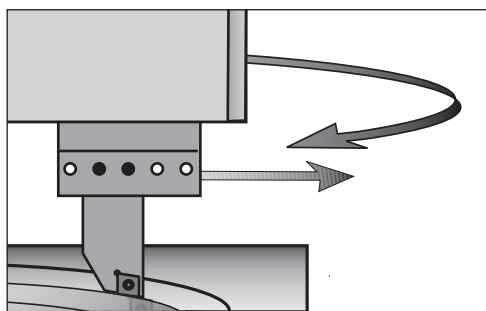

Working Principle

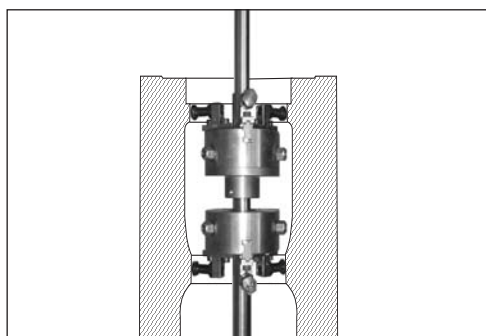

Pilot assembly for engine block

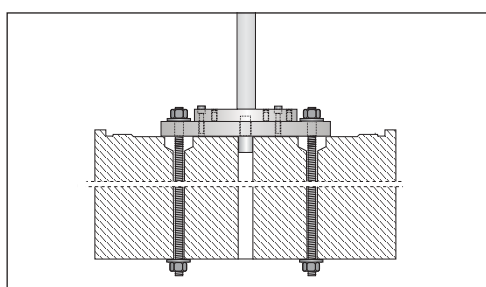

Pilot assembly for cylinder head

Working Principle:

The VD4HD/0° resurfaces the seating surface in a lathe-type facing action to the preset depth by the simultaneous application of both a rotary and a transverse feed motion to the single point cutting tool.

While the cutting tool rotates around the surface, a feed gear mechanism ensures a continuous outward transverse feed motion.

An adjustable stop can be provided as an option for limiting the outward feed motion.

Features:

The VD4HD motor drive unit of the machine is part of the modular VD4HD SYSTEM and, therefore, is only required, if no VD4HD motor drive unit is at hand.

The VD4HD/0° is centered by a pilot assembly which is designed to fit to the engine component to be serviced.

The motor drive unit is equipped with two motors to provide a smooth cutting action.

The speed of the drive motors is adjustable so that the cutting speed can be adapted to the diameter and material of the seating surface.

The operating voltage is of the low voltage type to eliminate electric hazards.

Specifications:

Capacity

Refacing diam. range

Head Type D4.1/0°

70 - 330 mm

Head Type D4.2/0°

75 - 430 mm

Head Type D4.5/0°

95 - 500 mm

Max. transverse feed travel length

35 mm

50 mm

50 mm

Feed Motions

Cutting speed

100 - 250 rpm

Transverse feed per revolution

0,05 mm

Electrical System

Operating voltage

max. 50 VDC

Rated current

max. 10 A

Universal input voltage (1ph. 50/60 Hz)

100-277VAC

Power input

0,6 kW

Dimensions and Weight

Length/Width/Height

410/125/400 mm

Net weight

approx. 18 kg

Ludwig Hunger GmbH

Graefelfinger Str. 146
81375 Munich/Germany

Tel.: +49 89 7091-0
Fax: +49 89 7091-26

sales@ludwig-hunger.de
www.ludwig-hunger.de