

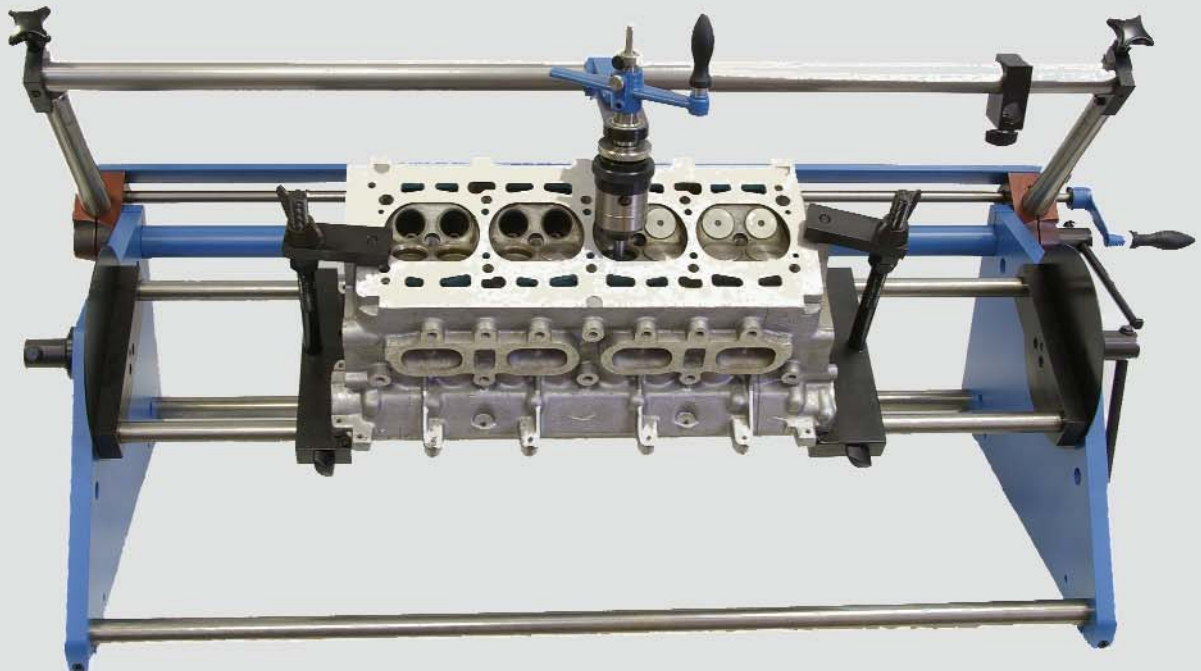

Hunger K2000

Universal Cylinder Head Stand

Removing valves,
Servicing valve seats and valve guides,
Installing valves.
An unique support for all jobs.



Including accessories for
compressing the valve springs.

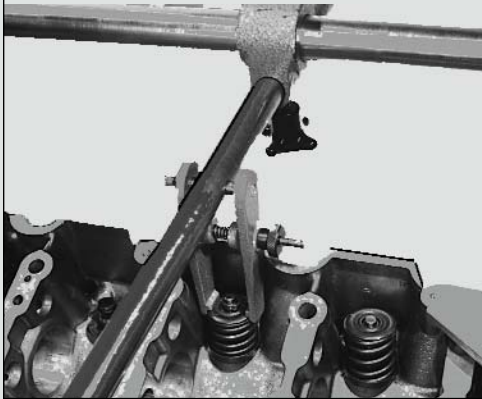

Dimensions and Weight

Length	1170mm
Width	530mm
Height	440 - 580mm
Net weight	approx. 60kg

K2000 Cylinder Head Stand

Universal support for cylinder heads
up to 820mm length.

Application

Motorcycle engine service
Car engine service
Truck engine service

Recommended

by leading engine manufacturers.

K2000 Components

Item	Description	Part No.
1.	K2000 Cylinder Head Stand	221 00 100

including a clamp for locking the swivelling guide arm of a Hunger valve refacing tool, a valve compressing attachment including a plunger \varnothing 26mm and a valve stop attachment for keeping the valves in place when compressing the valve springs.

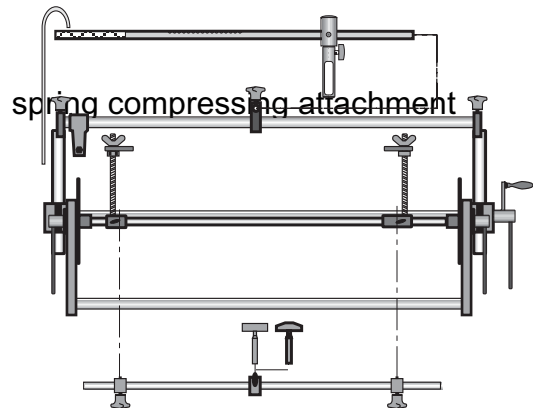

2.	Electromagnetic Support	221 40 100
----	--------------------------------	-------------------

for locking the swivelling guide arm of a valve seat refacing unit. Includes a 24 V power supply unit for connection to 230V \pm 10% AC.

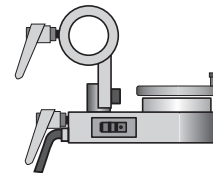

3.	Work Light	221 90 100
----	-------------------	-------------------

including clamping attachment for mounting to the head stand. The work light is equipped with a halogen lamp (12V, 20W). Includes a safety transformer for connection to 230V \pm 10% AC.

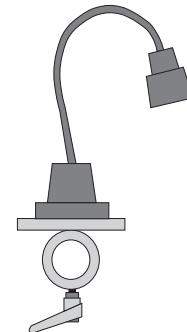

4.	Plunger \varnothing 22mm	221 20 058
----	--	-------------------

for valve springs located in very small recesses.



5.	Plunger \varnothing 30mm	221 20 054
----	--	-------------------

for very large valve springs



Ludwig Hunger GmbH

Graefelfinger Str. 146
81375 Munich/Germany

Tel.: +49 89 7091-0
Fax: +49 89 7091-26

info@ludwig-hunger.de
www.ludwig-hunger.de